

GROUND POWER UNIT

THC 5V 20 M

**Génération
28 Vdc**



STANDARD FEATURES

THE **THC 5V 20M** GROUND POWER UNIT HAVE BEEN DESIGNED TO SUPPORT ALL TYPE OF DC AIRCRAFT.

- ◆ 5 TH WHEEL (TURN TABLE) STEERINGS FOR A BETTER MANEUVRABILITY.
- ◆ LOW PROFILE POLYESTER CANOPY WITH TWO LARGE DOORS FOR A BETTER ACCESIBILITY.
- ◆ A LARGE FUEL TANK ALLOWS OVER 10 HS AT 75 % LOAD AND 8 HS AT 100 %.
- ◆ CURRENT LIMIT FROM 300 TO 2000 AMPS
- ◆ LINE DROP COMPENSATION AT NOMINAL POWER
- ◆ EMERGENCY PUSH BUTTON.
- ◆ 10 METERS OUTPUT CABLE.
- ◆ CE APPROVED

GÉNÉRAL AIRPORT SYSTEMS

Avenue Auguste Marius PEYRE - ZI La Grand Colle - BP 120
13110 - PORT de BOUC - FRANCE

☎ (33).4.42.40.72.40 - 📠 (33).4.42.40.72.46 - Email : TRACKAIRS@AOL.COM

TRACKAIR®

GROUND POWER UNIT

THC 5V 20 M

**Génération
28 Vdc**

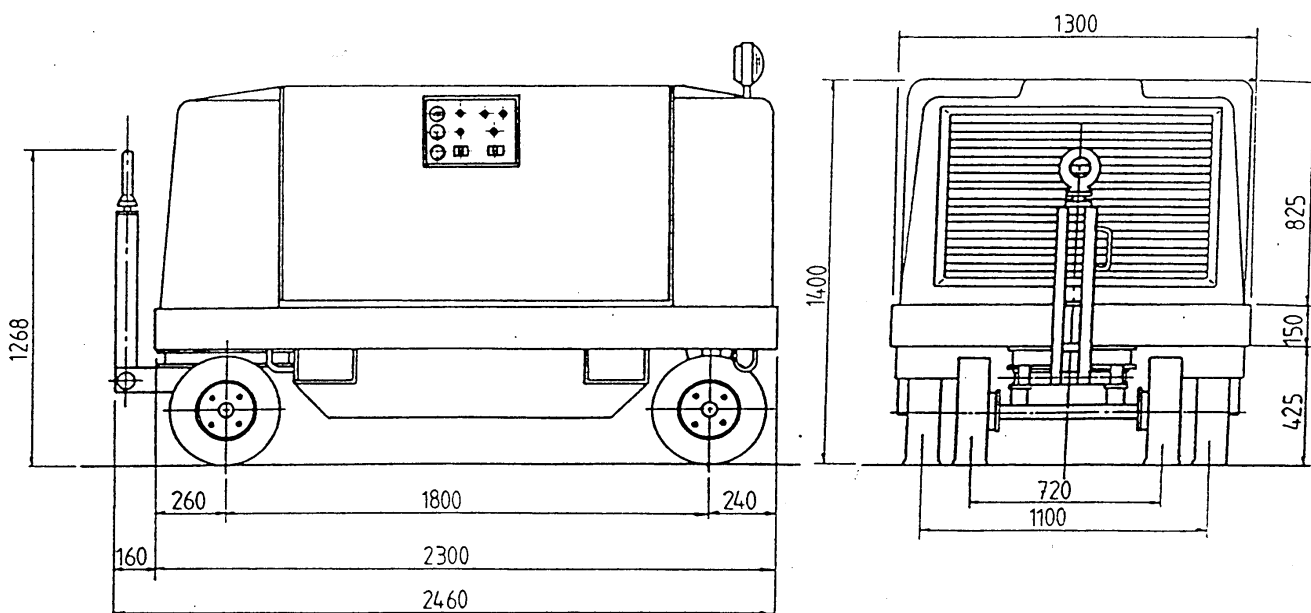

PERFORMANCE

Voltage..... 28,5 Vdc
Output Up to 2000 Amps Peak - 550 Amps continuous
Protection Overvoltage overload

ENGINE

Engine..... **Diesel IVECO 8045 E 00**
Générateur Alternator + Rectifier
Protection..... Low pressure oil
High coolant temperature.

CONTROL PANEL

Switches..... Contact - Start - Stop switch
Lights switch
Idle - Rpm switch
Contactor switch
Meters..... Hourmeter - Fuel gauge - Voltmeter - Ammeter

CONDITIONS OF USE

Temperature from -15° C to + 45° C
Towing speed 25 km/h

GÉNÉRAL AIRPORT SYSTEMS

Avenue Auguste Marius PEYRE - ZI La Grand Colle - BP 120
13110 - PORT de BOUC - FRANCE

☎ (33).4.42.40.72.40 - 📠 (33).4.42.40.72.46 - Email : TRACKAIRS@AOL.COM

TRACKAIR®